

# PRESSACAVI IN POLIAMMIDE



## PRESSACAVI IN POLIAMMIDE Filetto Passo "PG" UL - CSA

### COSTRUZIONE

**MATERIALE** Poliammide PA 6 V2  
**Guarnizione Interna** Policloroprene/Nitrile CR/NBR  
**Colore Standard** Grigio RAL 7001  
**Altri Colori** Grigio RAL 7035 e nero (SW)  
**Filetto** Passo PG

### PROPRIETA'

**Campo di Temperatura** -20°C sino +100°C  
**Grado di protezione** IP 68 - 5 bar  
**Infiammabilità** V2 sec. UL 94

**Cert. UL/CSA E140310**

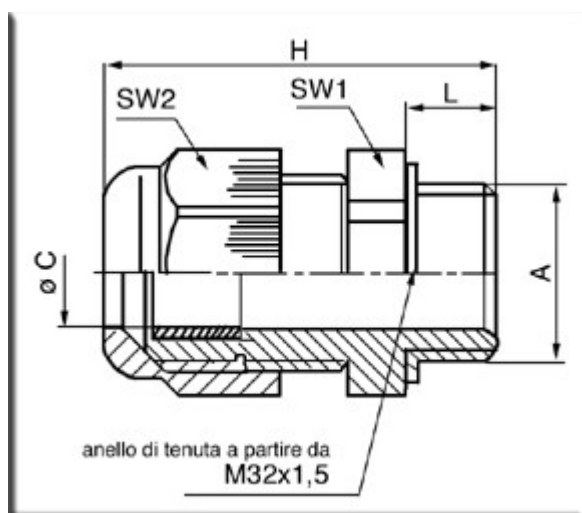

### PRESSACAVI IN POLIAMMIDE standard "PG"

Filetto A	Ø C mm	L mm	SW 1 mm	SW 2 mm	H mm	n° pezzi x conf	Codice Articolo
PG 7	3...6,5	8	15	15	30,5	100	50.007 PA 7001
PG 9	4...8	8	19	19	34	100	50.009 PA 7035
PG 11	5...10	8	22	22	37	100	50.011 PA SW
PG 13,5	6...12	9	24	24	39	100	50.013 PA ....
PG 16	10...14	10	27	27	42,5	50	50.016 PA ....
PG 21	13...18	11	33	33	47,5	50	50.021 PA ....
PG 29	18...25	11	42	42	53	25	50.029 PA ....
PG 36	22...32	13	53	53	61	10	50.036 PA ....
PG 42	30...38	13	60	60	65	5	50.042 PA ....
PG 48	34...44	14	65	65	67	5	50.048 PA ....

### PRESSACAVI IN POLIAMMIDE Filetto Lungo "PG"

Filetto A	Ø C mm	L mm	SW 1 mm	SW 2 mm	H mm	n° pezzi x conf	Codice Articolo
PG 7	3...6,5	15	15	15	37,5	100	50.007 PA15 7001
PG 9	4...8	15	19	19	41	100	50.009 PA15 7035
PG 11	5...10	15	22	22	44	100	50.011 PA15 SW
PG 13,5	6...12	15	24	24	45	100	50.013 PA15 ....
PG 16	10...14	15	27	27	47,5	50	50.016 PA15 ....
PG 21	13...18	15	33	33	51,5	50	50.021 PA15 ....
PG 29	18...25	15	42	42	57	25	50.029 PA15 ....
PG 36	22...32	18	53	53	66	10	50.036 PA15 ....